

VSI403US Digital Signal Processor

Ultra-Sleek Package (7mm x 7mm)



OVERVIEW

The VSI403US ZSP® Reference Silicon is an extremely low power 16-bit fixed-point digital signal processor (DSP) based on the VeriSilicon ZSP®400 DSP core, running less than 250 μ W per DSP MIPS (MMAC). The device is packaged in an ultra-sleek 144-pin LPGA package which is 7mm x7mm in size. VSI403US is designed for consumer handheld applications such as VoWiFi and audio. The VSI403US is capable of a maximum clock rate of 150 MHz for 600 MIPS peak performance and sustained effective throughput of 300DSP MIPS (MMACs). The device is also software compatible with all other products in the ZSP architecture, and offers an unrivalled combination of code density, performance and ease of use.

MEMORY

The internal memory structure of the VSI403US comprises of 16K words of instruction memory, 16K words of data memory, 16K words of configurable memory for instruction or data, 1K words of memory for boot loading and interrupt support and peripherals.

DMA

The DMA controller of the VSI403US supports zero-overhead instruction or data transfers to or from the entire 48K words of internal RAM to the memory interface unit, host processor interface, or a serial port. The eight DMA channels are segmented between four "indexed" and four "non-indexed" channels. Indexed channels have the ability to buffer data from either of the serial TDM interfaces, and non-indexed channels perform sequential accesses to or from internal memory. All DMA channels feature an auto-reload capability to restart transfers with no processor overhead.

FEATURES

- 150 MHz operation at 1.2V
- 2 high-speed serial/TDM ports (T1/E1 framer, H.100/H.110 bit stream compatible)
- Low power dissipation (50mW typical at 150 MHz)
- Sleep power mode consumes <20uW/MHz
- 48K words on-chip RAM
- 8-channel DMA controller
- On-board PLL for clock generation
- 2 on-board timers
- 8-bit host processor interface with hardware byte pack/unpack
- IEEE 1149.1-compliant JTAG port for in-system debug
- 144 LPGA packages (7mmx7mm)

BENEFITS

- 300 MMAC sustained DSP performance at 150MHz
- Direct interfacing to standard telecommunications interfaces, reducing system cost
- Low power per voice or audio channel
- Suitable for very low power applications
- High data throughput without processor overhead
- Flexibility to optimize power consumption
- High data bandwidth to off-chip devices
- Simple interfacing to industry-standard micros
- Low overhead on chip debug
- Ideal for low-cost VoIP designs

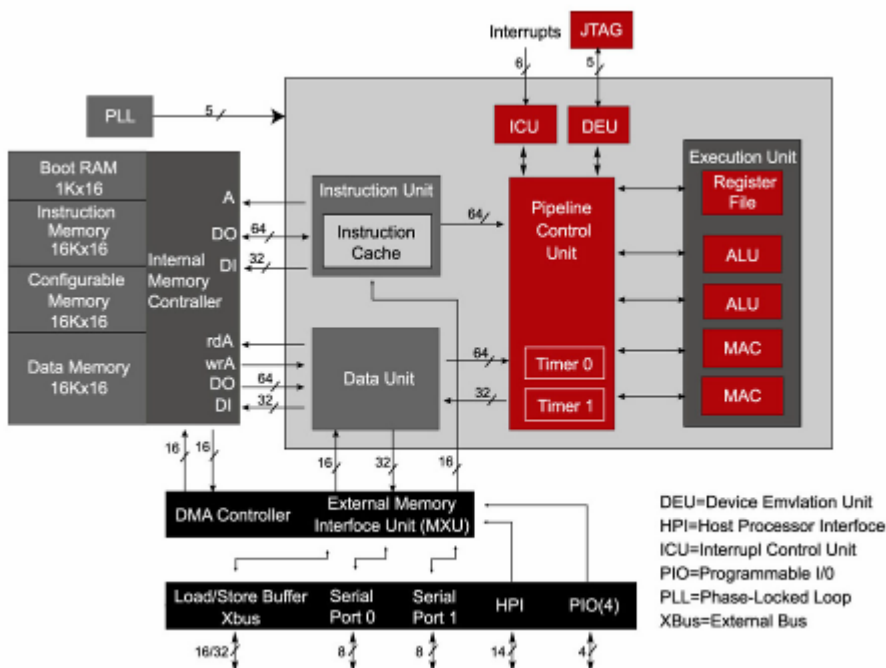

Figure 1. VSI403US Functional Block Diagram



VSI403US Digital Signal Processor

TIMERS

The VSI403US has two identical 16-bit on board timers for real-time interrupt generation. Each timer is fully programmable, and has a 6-bit prescaler and interrupt capability. The timers can automatically reload with the initial count so that periodic interrupts can be generated.

TDM SERIAL PORTS

The VSI403US provides two identical synchronous serial ports that support 8- or 16-bit active or passive transfers, which can be either burst or continuous, with a maximum clock speed of one-half the processor clock. Both serial ports support μ - and A-law hardware commanding and provide the programmable feature of a TDM (time division multiplex) mode that is compatible with T1/E1 framers or the local serial bus of H.100/H.110 interface devices. The TDM mode can also be used to establish a serial multiprocessor communication link with only three signals.

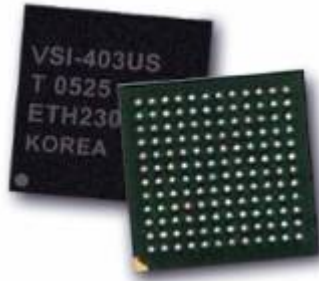

HOST PROCESSOR INTERFACE (HPI)

The Host Processor Interface, or HPI, is an asynchronous 8-bit parallel port that is used to interface with off-chip devices. It is compatible with both Motorola and Intel style memory interfaces, and supports word transfers. The maximum transfer rate for the HPI is one-third of the processor clock frequency. The HPI includes hardware support to pack/unpack bytes to/from 16-bit words, removing the overhead of this task from the ZSP400 core.

About ZSP Reference Silicon:

ZSP Reference Silicon is VeriSilicon's range of voice processors based on the ZSP400 DSP core, which support board-level voice products and enable quick prototyping of voice SoCs. These processors are ideal for VoIP customer premises equipment (CPE) for residential, SOHO and enterprise applications. They are also targeted for other voice-related applications such as compression, recognition, noise reduction and echo cancellation. For more information, please visit <http://www.verisilicon.com/Products & Solutions>

About VeriSilicon

VeriSilicon Holdings Co., Ltd ("VeriSilicon") is a fast growing silicon solutions company providing products and services that enable customers to meet their chip design objectives, accelerate development programs and deliver market proven silicon products - on time and at lower cost. VeriSilicon specializes in providing expert design services, market leading ZSP® licensable cores and platforms, industry standard semiconductor IP and scalable ASIC turnkey services across a broad range of application markets, including multimedia, voice and wireless communications. VeriSilicon has design, operation and sales and support offices in Santa Clara, California, Dallas, Texas, Shanghai and Beijing, China, Taipei, Taiwan, Tokyo, Japan, Nice, France and Seoul, Korea. For more information, visit www.verisilicon.com.

For more information please contact:

• US

VeriSilicon, Inc.
4699 Old Ironsides Dr., Suite 350
Santa Clara, CA 95054
Tel: +1 408 844 8560
Fax: +1 408 844 8563
E-mail: us-sales@verisilicon.com

VeriSilicon, Inc.

500North Central Expressway
Suite 430 Plano, Texas 75074
Tel: +1 972 244 5100
Fax: +1 972 244 5101
E-mail: us-sales@verisilicon.com

• China

VeriSilicon Microelectronics (Shanghai) Co., Ltd.
Building 1, No.200, Zhangheng Rd
Pudong New Area, Shanghai 201204
Tel: +86 21 51311118
Fax: +86 21 51311119

VeriSilicon Microelectronics (Beijing) Co., Ltd.

Rm A106, Information Center,
Zhongguancun Software Park
8 Dongbeiwang West Road,
Haidian District, Beijing 100193, P.R.C
Tel: +86 10 8282 5201
Fax: +86 10 8282 5201
E-mail: china-sales@verisilicon.com

• Taiwan

VeriSilicon Taiwan, Inc.
5F, No. 306, Sec.1., Neihu Road
Taipei 114, Wall Street Building, Taiwan.
Tel: +886 2 2656 2606
Fax: +886 2 2656 2604
E-mail: taiwan-sales@verisilicon.com

• Japan

VeriSilicon K.K.
The Imperial Tower, 8th floor
1-1-1 Uchisaiwaicho Chiyoda-ku
Tokyo, 100-0011 Japan
Tel: +81 3 3507 3005
Fax: +81 3 3507 3006
E-mail: japan-sales@verisilicon.com

• Europe

VeriSilicon, SARL
Les Algorithmes, Bat. Aristote A 2000 Route
des lucioles 06901 Sophia Antipolis, France
Tel: +33 4 9294 4892
Fax: +33 4 9294 4882
E-mail: europe-sales@verisilicon.com

• Korea

VeriSilicon, Korea.
B-1201, The O superium 1, 3001-2,
Bangbae 4-dong, Seocho-gu Seoul, 137-064, Korea
Tel: +82 2 6409 4506
Fax: +82 2 6409 4501
E-mail: korea-sales@verisilicon.com

© 2006 VeriSilicon Holdings Co., Ltd. All rights reserved worldwide. VeriSilicon, the VeriSilicon logo, ZSP and the ZSP logo are the trademarks of VeriSilicon Holdings Co., Ltd. in the United States and/or other jurisdictions. All other trademarks are the property of their respective holders.

