

ZSP800 – Licensable, High-Performance Application Oriented DSP Processor

ZSP800 Overview

The ZSP800 extends the successful ZSP product family and introduces the company's third generation ZSP processor architecture. The G3 architecture has been developed to meet the needs of high-performance applications, such as high-definition audio and wireless processing, and incorporates a number of innovative features to provide the right balance between silicon cost and processing. While offering the capabilities one would expect from a high-performance DSP, the ZSP800 does not suffer in

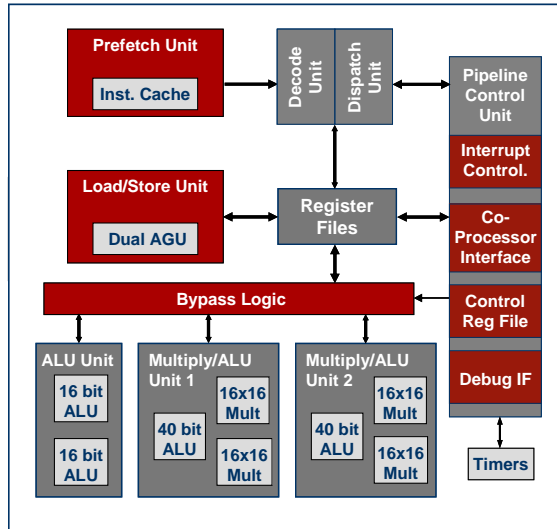

terms of clock speed and is able to achieve very high clock rates. For a 65 nm generic process, the eight-stage ZSP800 delivers approximately 450 MHz under worst case operating conditions with standard cell libraries. The ZSP800 also integrates a number of powerful execution units and parallel compute capabilities enabling multiple operations per clock cycle. The resulting combination of clock speed and processing provides unprecedented performance from a single-core solution, satisfying the high-end audio demands of applications such as Blu-Ray/HD-DVD players and HD DTV.

Native 32-bit Processing and High-Data Throughput

For high-precision applications, such as high-end audio, the ZSP G3 architecture incorporates extensive 32-bit capabilities and wide multiplier accumulators to provide native, high-throughput processing. To meet the potentially high data bandwidth required for these class of applications, the ZSP800 also supports up to a dual 64-bit load/store per clock cycle.

ZSP800 32-Bit Compute Capability

- | | | |
|-------------------------|---------------------|------------------------------------|
| • 40-bit ALUs | • 40 bit shifter | • 40-bit general purpose registers |
| • 32x32 MAC, 72 bit ACC | • 40 bit add, sub | |
| • 16x16 MAC, 40 bit ACC | • 32 bit address RF | • dual 64-bit load/store port |

Instruction Set Architecture

The ZSP800 orthogonal ISA supports a complete set of DSP instructions—multiple addressing modes, saturate/round options, single cycle dualx32 MAC, etc.—and features a number of unique application oriented instructions to significantly speed up processing. The resulting ZSP architecture achieves dramatic MHz savings when compared to other available processors in the market. An additional benefit is the G3 architecture backward compatibility with the ZSP G2, providing customers a maximum reusable platform.

High-end Audio ISA Examples

- 4 16-bit MUL/MAC operations per cycle or 2 complex MAC per cycle
- 2 40-bit MUL/MAC per cycle
- 1 32x32 with 72-bit result

Wireless/WiMAX ISA Examples

- 3 ACS per cycle—Viterbi
- 4 16-bit MUL/MAC operations per cycle or 2 complex MAC
- Per instruction conditional execution



ZSP800 HIGHLIGHTS

Advanced DSP architecture

- 8-stage pipeline
- 4+1 instructions per cycle
- Quad-MAC, Six-ALU
- Mixed 16/32/40-bit datapath for native 32-bit precision
- 72-bit multiplier accumulator
- 450 MHz for worst case operating conditions in a 65 nm

Application oriented ISA

- 16/32-bit width instructions
- Extended precision MAC
- Divide Assist, Norm, Viterbi

High-performance subsystem

- Dual 64-bit load/store units
- Innovative MSS support large TCM
- 4 GW addressable space
- AHB/AXI support
- Z.Turbo™ interface for integrating hardware accelerators

Backward compatible with

ZSP G2 Architecture

ZSP800 BENEFITS

- Significant cost savings via single-core operation for most use cases
- Large market-ready software code base for quick time to market
- Next generation ZSP architecture providing customers scalability for future designs

ZSP800 – Licensable, High-Performance Application Oriented DSP Processor

ZSP800 65 nm Performance Overview

VZ.AudioHD 65 nm Area

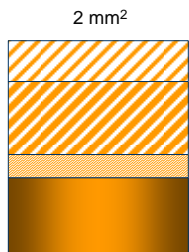

- System power ring, IO, etc.
- RAM Area (32/64 KB IMEM/DMEM)
- ZSP800 System Logic
- ZSP800 Processor Core Only

MHz Over a Range of HD Audio Use Cases (different codecs, bit-rates, sampling rates)

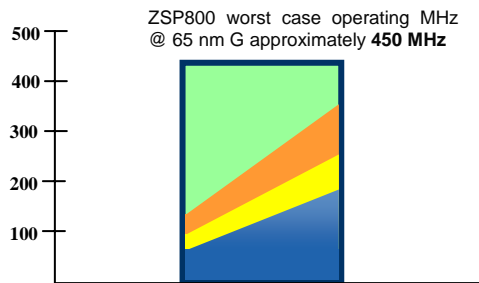

- Mixer and output processing
- Encode
- Primary and secondary audio decode
- Available Headroom

Robust Software And Hardware Development Tools

While VeriSilicon provides a comprehensive set of pre-optimized software modules for different market spaces, such as the VZ.AudioHD software suite, VeriSilicon recognizes the need for easy-to-use and powerful software development tools. The ZView SDK consists of a full software development tool chain to create, test and debug applications. Complex debug configurations, such as multi-core/multi-user, is seamlessly supported with ZView. In addition to cycle-accurate/instruction-accurate simulators, ZView also fully supports VeriSilicon hardware-based ZSP800 platforms providing system developers the fastest simulation speeds.

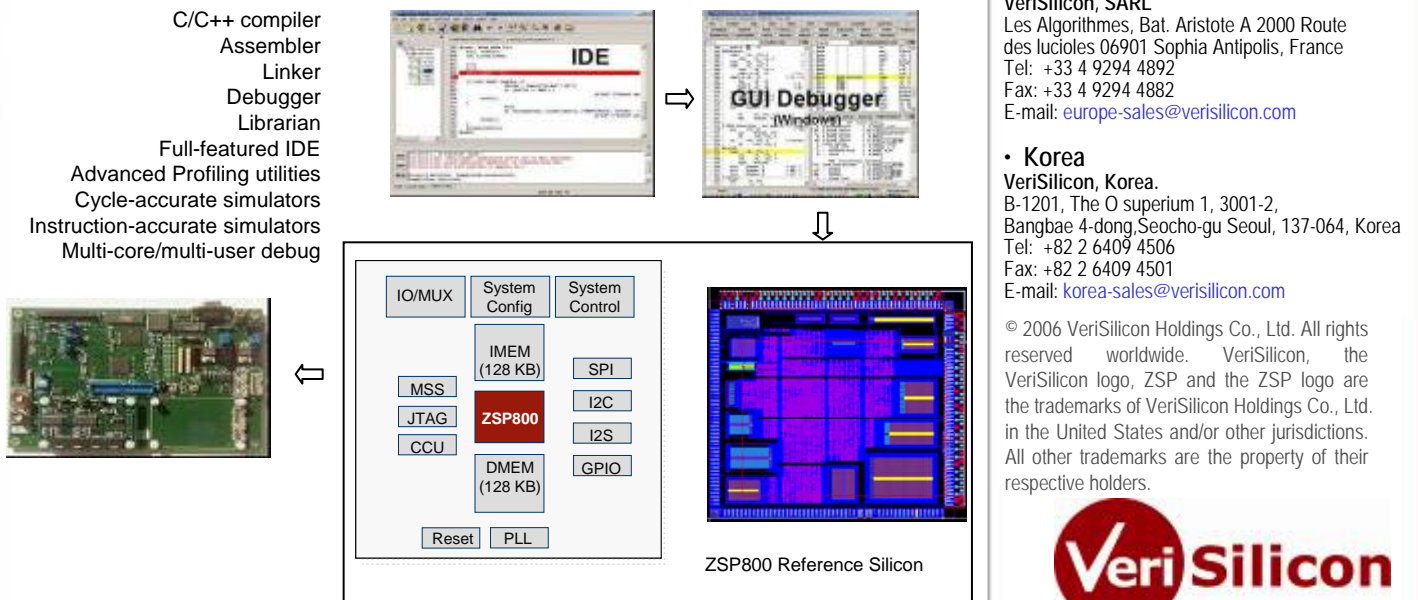

For more information please contact:

• US

VeriSilicon, Inc.
4699 Old Ironsides Dr., Suite 350
Santa Clara, CA 95054
Tel: +1 408 844 8560
Fax: +1 408 844 8563
E-mail: us-sales@verisilicon.com

VeriSilicon, Inc.

500 North Central Expressway
Suite 430 Plano, Texas 75074
Tel: +1 972 244 5100
Fax: +1 972 244 5101
E-mail: us-sales@verisilicon.com

• China

VeriSilicon Microelectronics (Shanghai) Co., Ltd.
Building 1, No.200, Zhangheng Rd
Pudong New Area, Shanghai 201204
Tel: +86 21 51311118
Fax: +86 21 51311119

VeriSilicon Microelectronics (Beijing) Co., Ltd.

Rm A106, Information Center,
Zhongguancun Software Park
8 Dongbeiwang West Road,
Haidian District, Beijing 100193, P.R.C
Tel: +86 10 8282 5201
Fax: +86 10 8282 5201
E-mail: china-sales@verisilicon.com

• Taiwan

VeriSilicon Taiwan, Inc.
5F, No. 306, Sec.1., Neihu Road
Taipei 114, Wall Street Building, Taiwan.
Tel: +886 2 2656 2606
Fax: +886 2 2656 2604
E-mail: taiwan-sales@verisilicon.com

• Japan

VeriSilicon K.K.
The Imperial Tower, 8th floor
1-1-1 Uchisaiwaicho Chiyoda-ku
Tokyo, 100-0011 Japan
Tel: +81 3 3507 3005
Fax: +81 3 3507 3006
E-mail: japan-sales@verisilicon.com

• Europe

VeriSilicon, SARL
Les Algorithmes, Bat. Aristote A 2000 Route
des lucioles 06901 Sophia Antipolis, France
Tel: +33 4 9294 4892
Fax: +33 4 9294 4882
E-mail: europa-sales@verisilicon.com

• Korea

VeriSilicon, Korea.
B-1201, The O superium 1, 3001-2,
Bangbae 4-dong, Seocho-gu Seoul, 137-064, Korea
Tel: +82 2 6409 4506
Fax: +82 2 6409 4501
E-mail: korea-sales@verisilicon.com

© 2006 VeriSilicon Holdings Co., Ltd. All rights reserved worldwide. VeriSilicon, the VeriSilicon logo, ZSP and the ZSP logo are the trademarks of VeriSilicon Holdings Co., Ltd. in the United States and/or other jurisdictions. All other trademarks are the property of their respective holders.

